

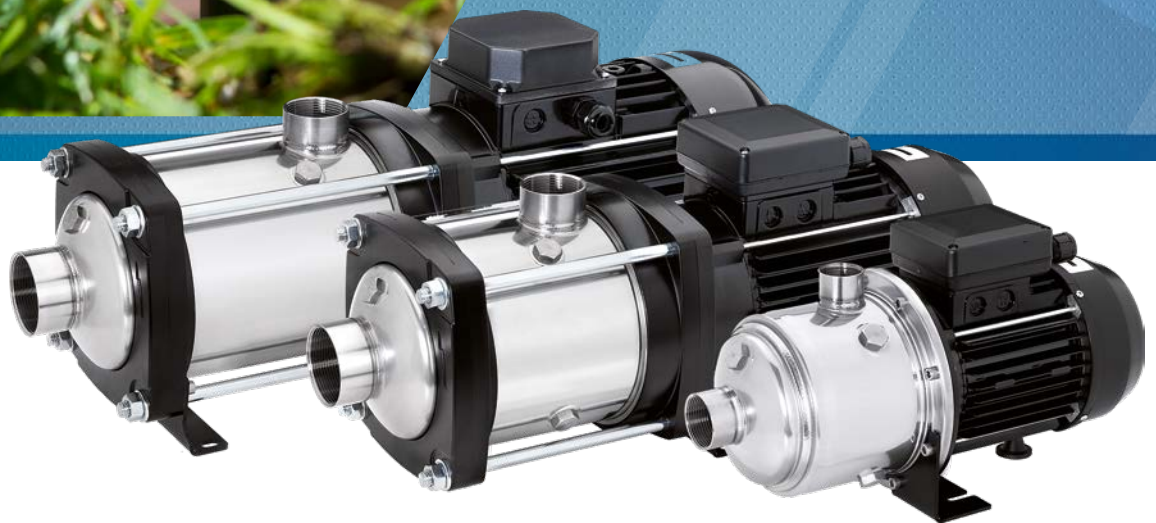

EH - EHsp SERIES 50 Hz

HORIZONTAL MULTISTAGE AND SELF-PRIMING PUMPS



INDEX

Stainless Steel Horizontal Multistage (EH) and self-priming (EHsp) Pumps	2
Family curves	3
Pump Identification Code	3
Tables of hydraulic performance at 50 Hz	4
Spare parts and materials	5
EH 3-5-9	6
EH 15-20.....	8
EHsp 3-5	10
Mechanical seal specifications	12
Motor specifications	13
Motor spare parts	14
EH Series - Technical data and performance curves	15
EH 3	16
EH 5	18
EH 9.....	20
EH 15.....	22
EH 20.....	24
EHsp Series - Technical data and performance curves	27
EHsp 3	28
EHsp 5	30

NOTE: Franklin Electric S.r.l. reserves the right to amend specification without prior notice

For the most up-to-date product information, visit franklinwater.eu.

STAINLESS STEEL HORIZONTAL MULTISTAGE (EH) AND SELF-PRIMING (EHsp) PUMPS

APPLICATIONS

- Small domestic and industrial systems / Domestic water supply
- Water distribution / pressure boosting
- Irrigation / Gardening / Sprinklers / Rainwater recovery
- Industrial plants / Wash down unit
- Cooling and chilling / Heating and conditioning / Air conditioning systems
- Pumping of clear non-loaded fluids
- Other various installations

FEATURES

- Compact close-coupled design, robust and corrosion resistant
- Superior efficiency and performance
- WRAS and ACS approved
- Flexible application base plate (only for EH)
- Floating neck ring in PPS
- Heavy duty oversize motor shaft
- Impellers and diffusers are made of stainless steel
- Easy maintenance
- Mechanical seal Type E0 = Carbon graphite / Ceramic alumina / EPDM: EH 3-5-9, EHsp 3-5
- Mechanical seal Type E1 = Carbon graphite / Silicon carbide / EPDM: EH 15-20

PUMP SPECIFICATIONS

- Flow: up to 29 m³/h (EH), up to 8 m³/h (EHsp)
- Head: up to 104 m (EH and EHsp)
- Connections: Rp threaded for inlet and outlet
- Maximum working pressure 10 Bar
- Maximum allowable amount of sand 50 g/m³ (EH)
- Maximum ambient temperature 40 °C
- Liquid temperature range (EH):
 - Minimum: from -15 °C to -10 °C according to gasket material
 - Maximum: +90 °C for domestic use (uses covered by EN standard 60335-2-41);
+110 °C only for industrial use (uses other than those covered by EN standard 60335-2-41)
- Liquid temperature range (EHsp): from 0 °C up to 35 °C
- The hydraulic characteristics are guaranteed, according to ISO standard 9906:2012, grade 3B

MOTOR SPECIFICATIONS

- Single-phase
- Three-phase motor efficiency class IE3
- Asynchronous, TEFC (Totally Enclosed, Fan-Cooled)
- 2 pole
- IP55 protection motor, Insulation class F
- Standard voltage:
 - Single-phase: 220-240 V ± 5 % (thermal protection built into the motor)
 - Three-phase: 220-240 V / 380-415 V ± 5 % up to 3 kW (thermal protection to be provided into the starter panel by the installer)
380-415 V / 660-690 V ± 5 % from 4 kW (thermal protection to be provided into the starter panel by the installer)
- Frequency of starts:
 - Max. 60 starts/hour for motor power up to 3 kW (with min. 1 minute resting time)
 - Max. 30 starts/hour for motor power from 4 kW (with min. 2 minute resting time)

AVAILABLE ON REQUEST

- Special mechanical seal (EH)
- Suction/discharge nozzles NPT
- Models with switch ON-OFF, 1.5 m of cable and Schuko plug (EHsp PLUG)

FAMILY CURVES

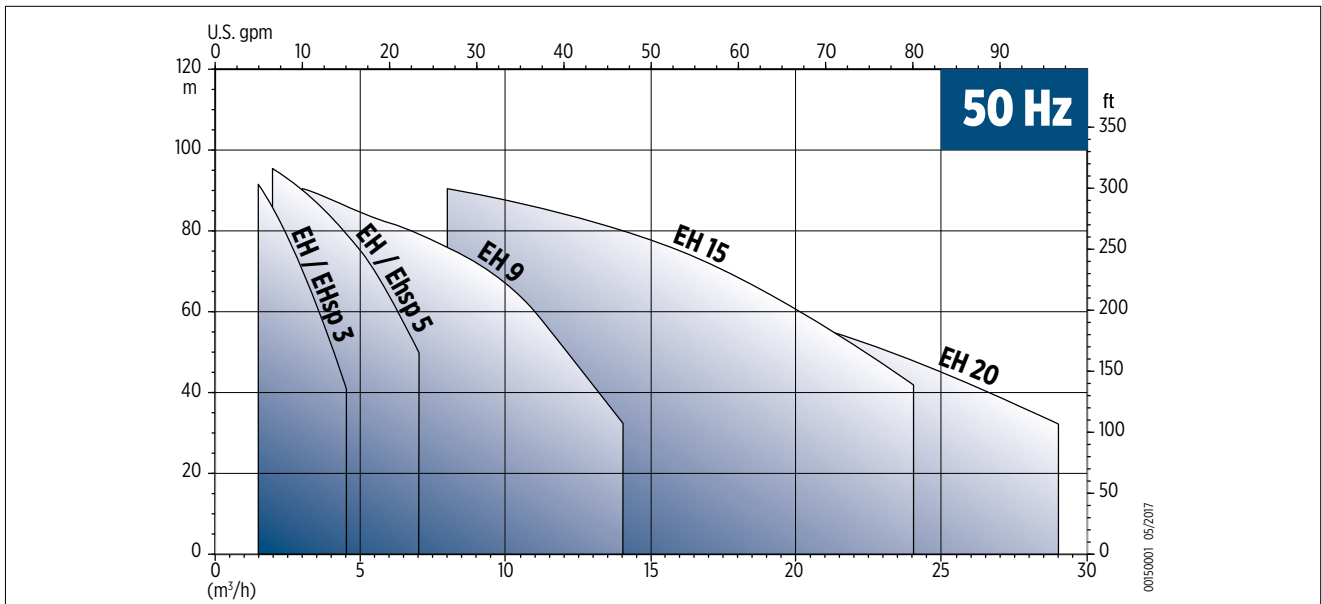

PUMP IDENTIFICATION CODE

15 / 03 I 022 T 5 E1

- Three-phase motor efficiency (IE3)
- Pumps speciality - Standard configuration if empty
- Mechanical seal type
- Frequency: 5 (50 Hz); 6 (60 Hz)
- M (Single phase); T (Three phase)
- Motor power kW x 10
- Pump material: I (AISI 304); N(AISI 316)
- Number of stages
- Nominal flow rate in m³/h
- Pump model: EH (standard)
EHsp (self-priming)

00140001EN 05/2017

TABLES OF HYDRAULIC PERFORMANCE AT 50 HZ

EH 3-5-9-15-20

Pump model	Q = DELIVERY																								
	l/min 0	25	33	42	50	58	67	75	83	92	100	117	133	150	167	183	233	267	300	333	367	417	467	483	
	m ³ /h 0	1.5	2	2.5	3	3.5	4	4.5	5	5.5	6	7	8	9	10	11	14	16	18	20	22	25	28	29	
	US GMP 0																								
	6.6	8.8	11.0	13.2	15.4	17.6	19.8	22.01	24.2	26.4	30.8	35.2	39.6	44.02	48.4	61.6	70.4	79.2	88.05	96.8	110.07	123.2	127.6		
	H = TOTAL M.HEAD OF WATER COLUMN [m]																								
EH 3/2	23	21	19.5	18	16.5	14.5	12.5	10																	
EH 3/3	33.5	30.5	29	26.5	24	21	17.5	14																	
EH 3/4	44.5	40	37.5	34.5	31	27	23	18																	
EH 3/5	55	49	46	42	37	32.5	27	21																	
EH 3/6	67.5	61	57	53	47	41.5	35	28																	
EH 3/7	78	70.5	66	60.5	54	47.5	40	32																	
EH 3/8	90	82	77	71	64	56	47	38																	
EH 3/9	101	91.5	85.5	79	70.5	61.5	52	41																	
EH 5/2	23.5		21.5	21	20.5	19.5	19	18	17	16	15	11.5													
EH 5/3	34.5		31.5	31	29.5	28.5	27.5	26	25	23	21	16													
EH 5/4	46.5		43	42	41	39.5	38	36	34	32	29	23													
EH 5/5	58		53	51.5	50	48.5	46.5	44	41.5	38.5	35.5	27.5													
EH 5/6	70		64.5	63	61	59	56.5	54	51	47.5	43.5	34													
EH 5/7	81.5		74.5	72.5	70	68	65	61.5	58	54	49.5	38.5													
EH 5/8	92.5		84	82	79	76.5	73	69	65	60	54.5	42													
EH 5/9	104		95.5	93	90.5	87.5	83.5	79.5	75	70	64	50													
EH 9/2	23.5				22	21.5	21	20.5	20	20	19.5	18.5	18	17	15.5	13.5	6.5								
EH 9/3	35.5				33	32.5	32	31.5	31	30.5	30	28.5	27.5	26	24	21	11								
EH 9/4	48				45	44.5	43.5	43	42	41.5	41	39.5	38	36	33	29.5	16								
EH 9/5	59.5				55.5	55	54	53	52	51	50	48.5	46.5	44	40.5	36	18.5								
EH 9/6	71				66	65	64	62.5	61.5	60	59	57	54.5	51	47	41.5	21								
EH 9/7	84				79.5	78.5	77.5	76	74.5	73.5	72	70	67	64	59.5	53.5	29.5								
EH 9/8	96				90.5	89.5	88	86	84.5	83	82	79.5	76	72.5	67	60	32.5								
EH 15/2	29													26	25.5	25.5	25	23	21.5	19.5	17.5	14.5	9.5		
EH 15/3	44													39.5	39	38	37.5	34.5	32.5	29.5	26	22	14.5		
EH 15/4	58.5													53	52	51.5	50.5	47	44	40	35.5	30	20		
EH 15/5	73													65.5	64.5	63.5	62.5	57.5	54	49	43.5	36.5	24		
EH 15/6	87.5													79.5	78	77	75.5	71	67	61.5	54	46	31.5		
EH 15/7	102													92	90.5	89	87.5	82	77.5	70.5	62	52.5	36		
EH 20/2	31													28.5	28	27.5	27	26	25	24	22.5	20.5	16.5	12	10
EH 20/3	46.5													43	42.5	41.5	41	39.5	38	36.5	34.5	31.5	25.5	19	16
EH 20/4	62.5													58	57	56	55.5	53.5	51.5	49.5	46.5	42.5	34.5	26	22
EH 20/5	78.5													72.5	71.5	70.5	69.5	67	64.5	62	58.5	53.5	43.5	32.5	28

EHsp 3-5

Pump model	Q = DELIVERY																							
	l/min 0	25	33	42	50	58	67	75	83	92	100	117	133	150	167	183	233	267	300	333	367	417	467	483
	m ³ /h 0	1.5	2	2.5	3	3.5	4	4.5	5	5.5	6	7	8	9	10	11	14	16	18	20	22	25	28	29
	US GMP 0																							
	6.6	8.8	11.0	13.2	15.4	17.6	19.8	22.01	24.2	26.4	30.8	35.2	39.6	44.02	48.4	61.6	70.4	79.2	88.05	96.8	110.07	123.2	127.6	
	H = TOTAL M.HEAD OF WATER COLUMN [m]																							
EHsp 3/4	43.5	38.0	35.0	32.0	28.5	24.5	20.0	15.0																
EHsp 3/5	54.0	46.5	43.0	39.0	34.0	29.0	23.5	17.0																
EHsp 3/4T	44.0	38.5	35.5	32.0	29.0	25.0	20.0	15.0																
EHsp 3/5T	54.0	47.0	43.0	39.0	35.0	30.0	24.0	18.0																
EHsp 5/4	45.0		42.0	41.0	39.5	38.0	36.0	34.0	32.0	30.0	27.0	20.0												
EHsp 5/5	56.0		51.5	50.0	48.0	46.5	44.0	42.0	39.0	36.0	33.0	24.0												
EHsp 5/4T	45.0		41.5	40.0	39.0	37.0	36.0	34.0	32.0	30.0	26.5	20.0												
EHsp 5/5T	55.5		51.0	49.0	47.5	45.5	43.0	41.0	38.0	35.0	31.5	23.0												



Spare parts and materials

EH 3-5-9

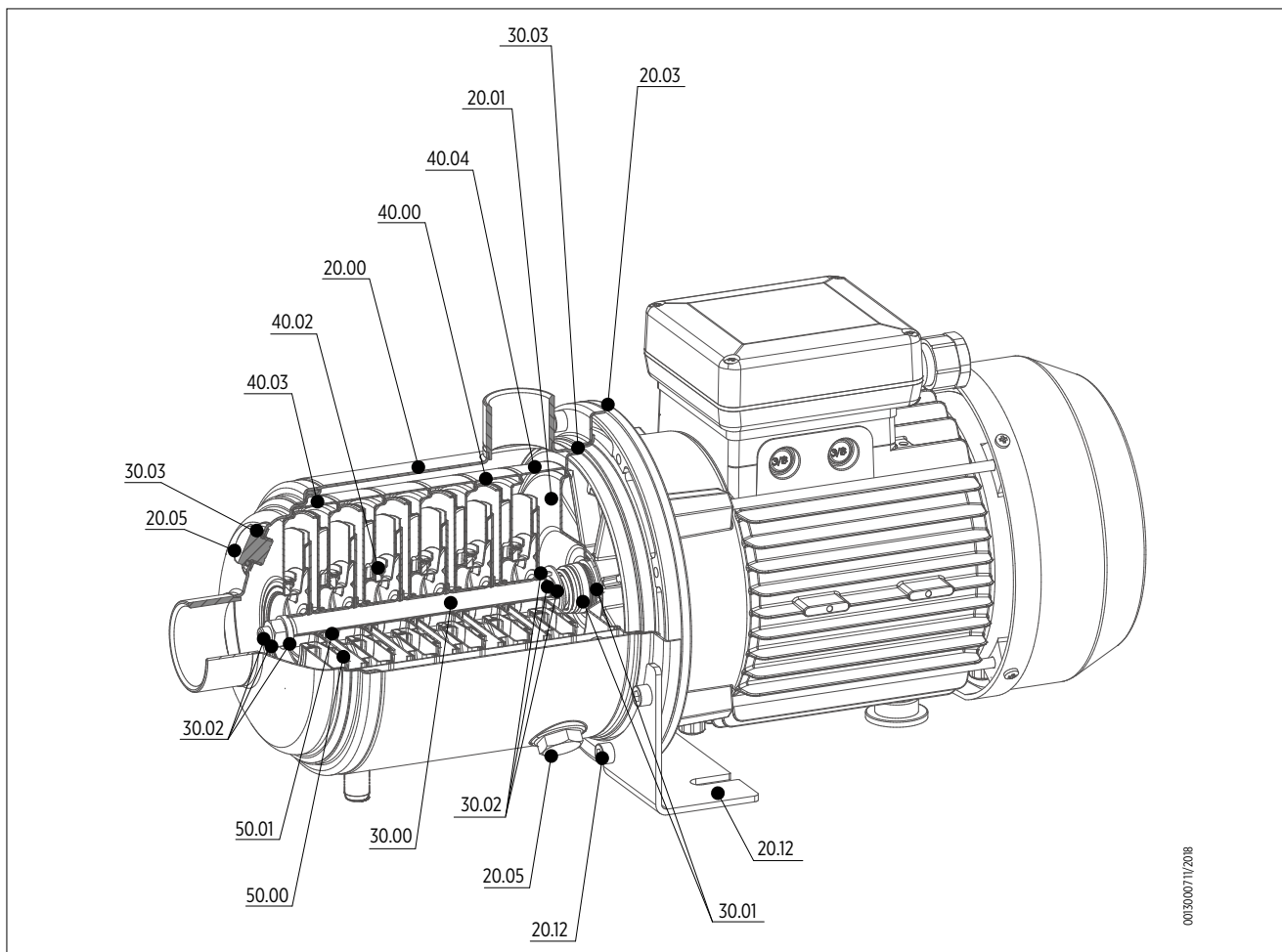

001300011/2018

PARTS IN CONTACT WITH LIQUID

Ref. No.	Part description	Material	Standard			
			I version		N version	
			ASTM/AISI	DIN/EN	ASTM/AISI	DIN/EN
20.00	Outer case	Stainless steel	AISI 304	1.4301	AISI 316 L	1.4404
20.01	Mechanical seal housing	Stainless steel	AISI 304	1.4301	AISI 316 L	1.4404
20.05	Filling plug	Stainless steel	AISI 304	1.4301	AISI 316	1.4401
30.00	Pump shaft	Stainless steel	AISI 304	1.4301	AISI 316	1.4401
30.01	Kit mechanical seal	Carbon graphite / Ceramic alumina / EPDM	-	-	-	-
30.02	Mechanical seal fastening kit	Stainless steel	AISI 304	1.4301	AISI 316	1.4401
30.03	Kit O-rings	EPDM	-	-	-	-
40.00	Stage housing and diffuser	Stainless steel	AISI 304	1.4301	AISI 316 L	1.4404
40.02	Floating neck ring	Stainless steel and PPS	AISI 304	1.4301	AISI 316 L	1.4404
40.03	Initial stage housing	Stainless steel	AISI 304	1.4301	AISI 316 L	1.4404
40.04	Last Stage with diffuser	Stainless steel	AISI 304	1.4301	AISI 316 L	1.4404
50.00	Impeller	Stainless steel	AISI 304	1.4301	AISI 316 L	1.4404
50.01	Impeller spacers	Stainless steel	AISI 304	1.4301	AISI 316 L	1.4404

SPARE PARTS LIST

Ref. No.	Part description
20.00	Outer case
20.01	Mechanical seal housing
20.03	Motor bracket
20.05	Filling plug
20.12	Support foot and screws
30.00	Pump shaft
30.01	Kit mechanical seal
30.02	Mechanical seal fastening kit

Ref. No.	Part description
30.03	Kit O-rings
40.00	Stage housing and diffuser
40.02	Floating neck ring
40.03	Initial stage housing
40.04	Last Stage with diffuser
50.00	Impeller
50.01	Impeller spacer

EH 15-20

CONFIGURATION UP TO 3 KW

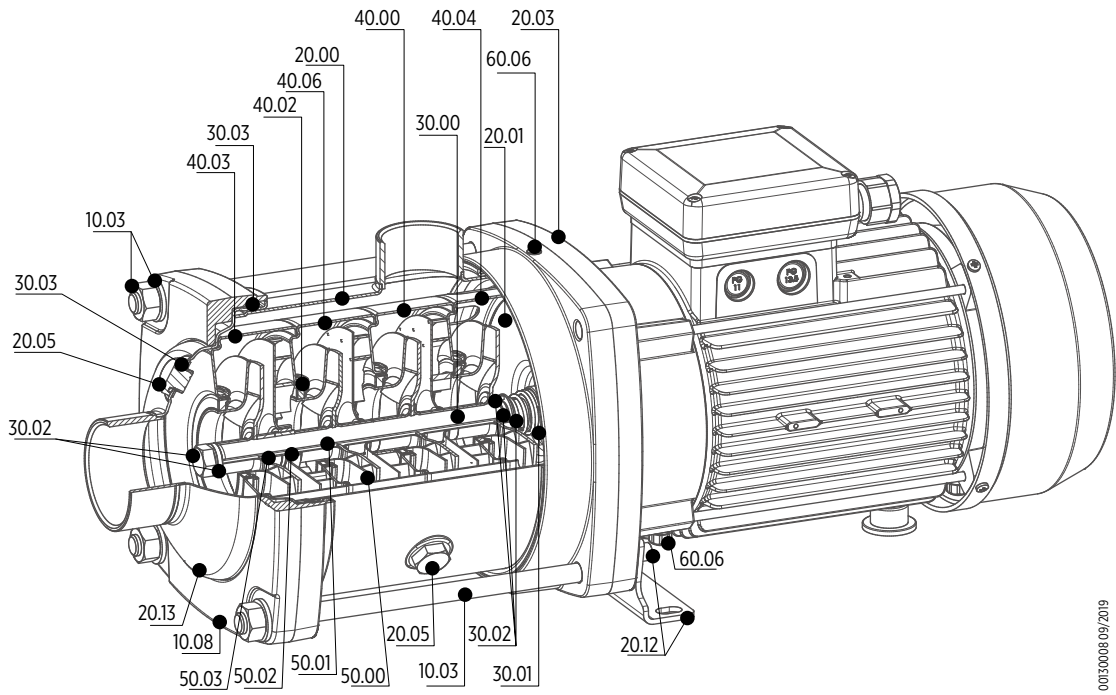

00150008 09/2019

CONFIGURATION FROM 4 KW

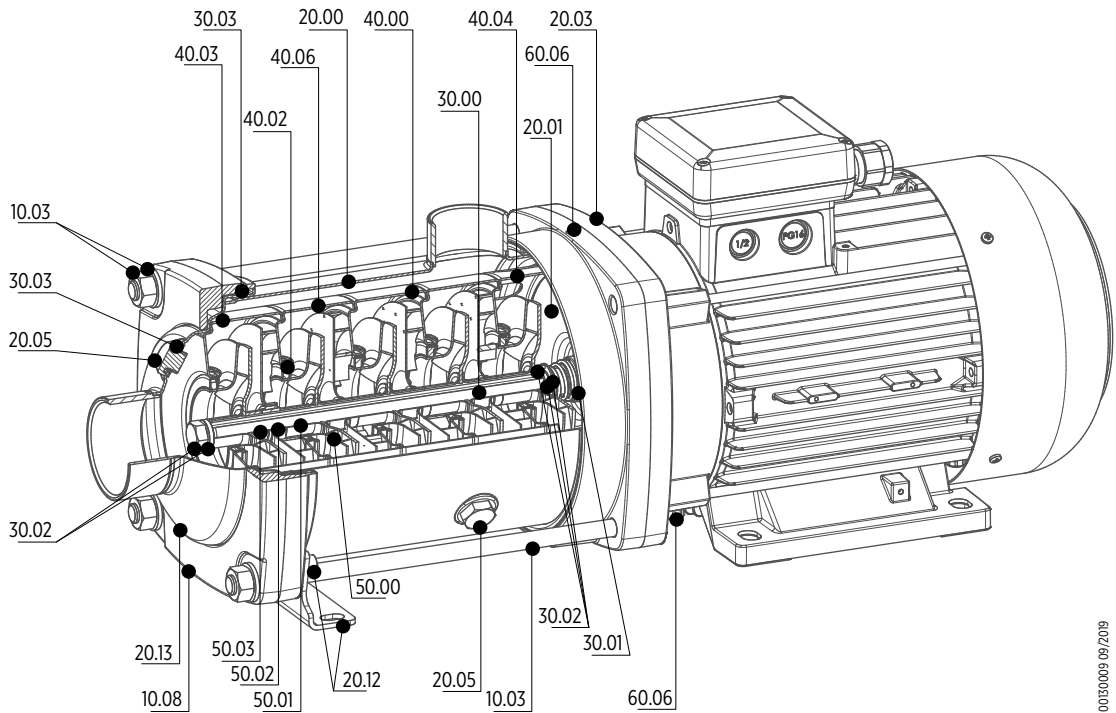

00150009 09/2019

PARTS IN CONTACT WITH LIQUID

Ref. No.	Part description	Material	Standard			
			I version		N version	
			ASTM	DIN/EN	ASTM	DIN/EN
20.00	Outer case	Stainless steel	AISI 304	1.4301	AISI 316 L	1.4404
20.01	Mechanical seal housing	Stainless steel	AISI 304	1.4301	AISI 316	1.4401
20.05	Filling plug	Stainless steel	AISI 304	1.4301	AISI 316	1.4401
20.13	Inlet cover	Stainless steel	AISI 304	1.4301	AISI 316	1.4401
30.00	Pump shaft	Stainless steel	AISI 304	1.4301	AISI 316	1.4401
30.01	Kit mechanical seal	Carbon graphite / Silicon carbide (SiC) / EPDM	-	-	-	-
30.02	Mechanical seal fastening kit	Stainless steel	AISI 304	1.4301	AISI 316	1.4401
30.03	Kit O-rings	EPDM	-	-	-	-
40.00	Stage housing and diffuser	Stainless steel	AISI 304	1.4301	AISI 316 L	1.4404
40.02	Floating neck ring	Stainless steel and PPS	AISI 304	1.4301	AISI 316 L	1.4404
40.03	Initial stage housing	Stainless steel	AISI 304	1.4301	AISI 316 L	1.4404
40.04	Last Stage with diffuser	Stainless steel	AISI 304	1.4301	AISI 316 L	1.4404
40.06	Stage housing and diffuser with bearing	Stainless steel, Tungsten carbide (WC)	AISI 304	1.4301	AISI 316 L	1.4404
50.00	Impeller	Stainless steel	AISI 304	1.4301	AISI 316 L	1.4404
50.01	Impeller spacer	Stainless steel	AISI 304	1.4301	AISI 316 L	1.4404
50.02	Intermediary sleeve	Tungsten carbide (WC)	-	-	-	-
50.03	Intermediary sleeve spacer	Stainless steel	AISI 304	1.4301	AISI 316 L	1.4404

SPARE PARTS LIST

Ref. No.	Part description
10.03	Tie bolts, washers and nuts
10.08	Pre-load flange
20.00	Outer case
20.01	Mechanical seal housing
20.03	Motor bracket
20.05	Filling plug
20.12	Support foot and screws
20.13	Inlet cover
30.00	Pump shaft
30.01	Kit mechanical seal
30.02	Mechanical seal fastening kit

Ref. No.	Part description
30.03	Kit O-rings
40.00	Stage housing and diffuser
40.02	Floating neck ring
40.03	Initial stage housing
40.04	Last Stage with diffuser
40.06	Stage housing and diffuser with bearing
50.00	Impeller
50.01	Impeller spacer
50.02	Intermediate sleeve
50.03	Intermediate sleeve spacer
60.06	Kit motor spare components

EHsp 3-5

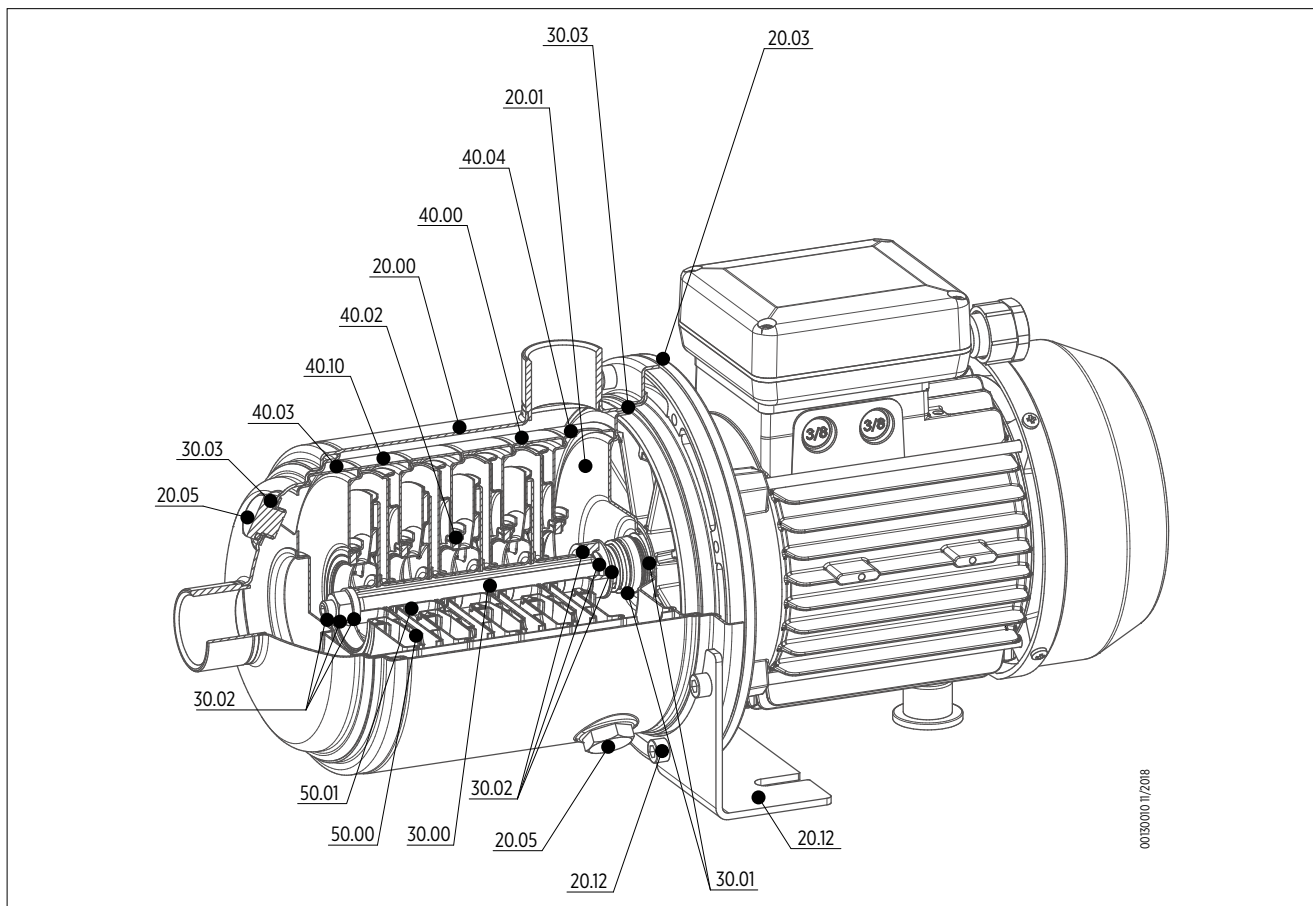

PARTS IN CONTACT WITH LIQUID

Pos.	Part description	Material	Standard	
			ASTM	DIN/EN
20.00	Outer case	Stainless steel	AISI 304	1.4301
20.01	Mechanical seal housing	Stainless steel	AISI 304	1.4301
20.05	Filling plug	Stainless steel	AISI 304	1.4301
30.00	Pump shaft	Stainless steel	AISI 304	1.4301
30.01	Mechanical seal	Carbon graphite / Ceramic alumina / EPDM	-	-
30.02	Mechanical seal fastening kit	Stainless steel	AISI 304	1.4301
30.03	Kit O-rings	EPDM	-	-
40.00	Stage housing and diffuser	Stainless steel	AISI 304	1.4301
40.02	Floating neck ring	Stainless steel and PPS	AISI 304	1.4301
40.03	Initial stage housing	Stainless steel	AISI 304	1.4301
40.04	Last Stage with diffuser	Stainless steel	AISI 304	1.4301
40.10	Stage housing with priming valve	Stainless steel	AISI 301 and 304	1.4310 and 1.4301
50.00	Impeller	Stainless steel	AISI 304	1.4301
50.01	Impeller spacer	Stainless steel	AISI 304	1.4301

SPARE PARTS LIST

Ref. No.	Part description
20.00	Outer case
20.01	Mechanical seal housing
20.03	Motor bracket
20.05	Filling plug
20.12	Support foot and screws
30.00	Pump shaft
30.01	Kit mechanical seal
30.02	Mechanical seal fastening kit

Ref. No.	Part description
30.03	Kit O-rings
40.00	Stage housing and diffuser
40.02	Floating neck ring
40.03	Initial stage housing
40.04	Last Stage with diffuser
40.10	Stage housing with priming valve
50.00	Impeller
50.01	Impeller spacer

MECHANICAL SEAL SPECIFICATIONS

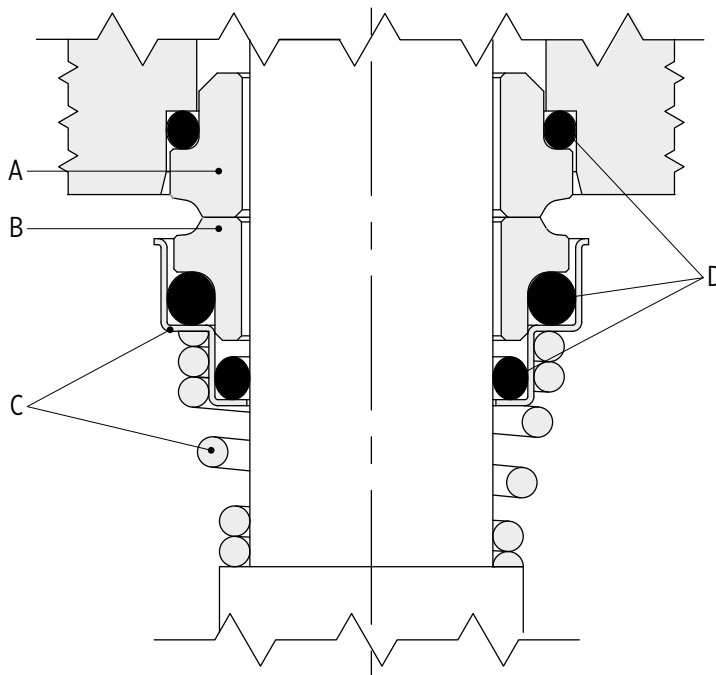

L0759 2005100

STANDARD VERSION

Model	Type				Position				Temperature [°C]
					A Stationary part	B Rotating part	C Other components	D Elastomers	
EH 3 - 5 - 9 / EHsp 3 - 5									
E0	V	B	G	E	Ceramic alumina	Carbon graphite	AISI 316	EPDM	-15 ÷ +110
EH 15 -20									
E1	B	Q	G	E	Carbon graphite	Silicon carbide	AISI 316	EPDM	-15 ÷ +110

AVAILABLE ON REQUEST (ONLY FOR EH)

Model	Type				Position				Temperature [°C]
					A Stationary part	B Rotating part	C Other components	D Elastomers	
E2	Q	Q	G	E	Silicon Carbide	Silicon Carbide	AISI 316	EPDM	-15 ÷ +110
V3*	Q	Q	G	V	Silicon Carbide	Silicon Carbide	AISI 316	FKM	-10 ÷ +110
V8*	Q	U	G	V	Silicon Carbide	Tungsten Carbide	AISI 316	FKM	-10 ÷ +110

* on request version with stopper pin

Type	Material
B	Carbon graphite
E	EPDM
G	AISI 316
Q	Silicon carbide
V	FKM
V	Ceramic alumina
U	Tungsten carbide

MOTOR SPECIFICATIONS

- Asynchronous, TEFC (Totally Enclosed, Fan-Cooled)
- 2 pole
- Protection degree: IP55
- Insulation class: F
- Frequency of starts:
 - Max. 60 starts/hour for motor power up to 3 kW (with min. 1 minute resting time)
 - Max. 30 starts/hour for motor power from 4 kW (with min. 2 minute resting time)

SINGLE-PHASE VERSION AT 50 HZ

- Standard voltage 220-240 V \pm 5%
- Thermal protection built into the motor

P _n [kW]	MOTOR SIZE	INPUT CURRENT I _n [A]	Capacitor		230 V - 50 Hz						
			230V	μF	V	η _N [min ⁻¹]	I _s /I _N	η %	cos φ	T _N [Nm]	T _s /T _N
0.33	71	2.50	16	450	2920	6.5	64.8	0.88	1.08	1.00	1.60
0.45	71	3.00	16	450	2890	5.4	69.7	0.92	1.5	0.72	1.60
0.55	71	3.50	16	450	2860	4.6	72.6	0.94	1.83	0.59	1.85
0.75	71	4.67	16	450	2790	3.5	72.2	0.97	2.56	0.42	1.87
0.9	71	5.45	30	450	2875	4.8	75.3	0.93	3	0.47	1.67
1.1	71	6.60	30	450	2820	3.9	77.0	0.96	3.7	0.38	1.86
1.3	80	7.46	30	450	2860	4.2	80.8	0.94	4.35	0.57	1.86
1.5	80	8.56	30	450	2830	3.6	79.9	0.95	5.05	0.50	1.92
1.85	80	10.90	30	450	2760	2.8	76.6	0.96	6.4	0.39	2.40
2.2	90	12.60	60	450	2870	2.2	76.7	0.99	7.3	0.51	1.99

THREE-PHASE VERSION AT 50 HZ

- IE3 Premium Efficiency Motors
- IE efficiency according to IEC 60034-30-1:2014
- Electrical performance according to IEC 60034-2-1:2007
- Standard voltage:
 - 220-240 / 380-415 V \pm 5 % up to 3 kW
 - 380-415 / 660-690 V \pm 5 % from 4 kW
- Thermal protection to be provided into the starter panel by the installer

P _n [kW]	Rendimento / Efficiency η _n %						IE
	Δ 230 V Y 400 V			Δ 400 V Y 690 V			
	4/4	3/4	2/4	4/4	3/4	2/4	
0.75	80.9	81.5	79.6	-	-	-	3
1.1	82.7	84.6	84.2	-	-	-	
1.5	84.3	85.7	85.3	-	-	-	
2.2	86.1	86.7	85.4	-	-	-	
3	87.1	87.5	86.1	-	-	-	
4	-	-	-	88.1	88.7	87.7	
5.5	-	-	-	89.2	89.4	88.1	

P_N [kW]	MOTOR SIZE	N. of poles	f_N [Hz]	400 V 50 Hz				
				$\cos \phi$	I_s / I_N	T_N [Nm]	T_s / T_N	T_M / T_N
0.75	71	2	50	0.83	6.8	2.6	3.6	3.7
1.1	71			0.82	5.9	3.7	3.2	3.1
1.5	80			0.79	6.8	5.1	3.2	3.2
2.2	90			0.8	9.6	7.3	4.3	4.4
3	90			0.83	9.6	9.9	4.7	4.9
4	100			0.85	8.1	13.2	2.8	3
5.5	112			0.81	8.4	18.1	4.3	4.5

P_N [kW]	VOLTAGE U_N				n_N [min ⁻¹]	Motor operating conditions		
	Δ 230 V	Y 400 V	Δ 400 V	Y 690 V		Altitude Above Sea Level [m]	T. amb min/max [°C]	ATEX
	I_N [A]							
0.75	2.8	1.6	-	-	2800	≤ 1000	-15 / 40	No
1.1	4.1	2.3	-	-	2840			
1.5	5.7	3.3	-	-	2830			
2.2	8.0	4.6	-	-	2880			
3	10.4	6.0	-	-	2900			
4	-	-	7.7	4.4	2900			
5.5	-	-	11.0	6.4	2900			

MOTOR SPARE PARTS

Ref. No.	Part description
20.03	Motor bracket
20.06	Kit bearings
60.01	Motor housing and stator
60.02	Bearing housing
60.03	Fan
60.04	Fan cover and screws
60.05	Motor tie rods
60.06	Kit motor spare components
60.07	Motor housing foot
60.08	Terminal box cover and base
60.09	Terminal board

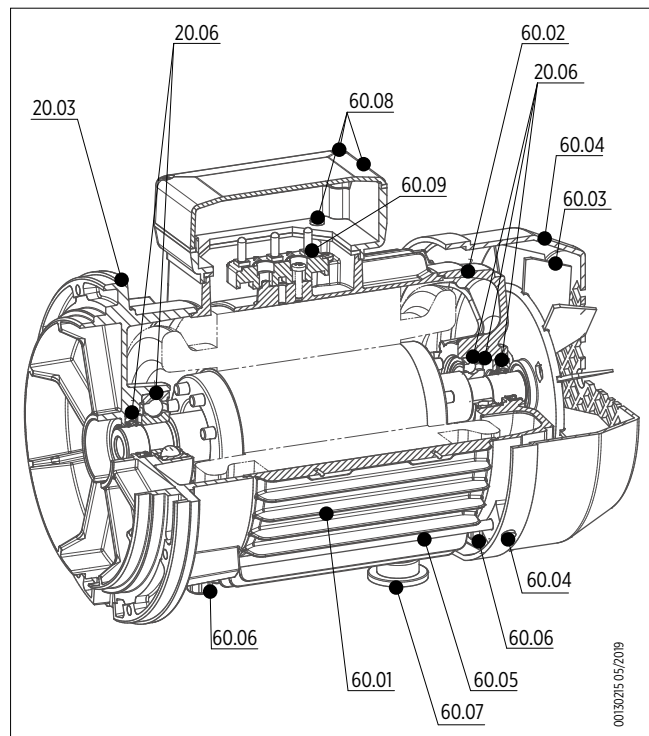

EH Series

Technical data and performance curves

EH 3 - TECHNICAL DATA

1 ~ ELECTRIC PUMP TECHNICAL DATA

Pump model	Motor Size	MOTOR NOMINAL POWER		INPUT POWER [kW]	Capacitor 450V μ F	INPUT CURRENT [A]	Dimensions [mm]						Weight [Kg]	
		[kW]	[HP]				A	F	\varnothing B	H	L1	L2		L3
EH 3/2	71	0.33	0.45	0.46	16	2.5	103	361	144	207	70	101	-	11.2
EH 3/3	71	0.45	0.6	0.60	16	3.0	103	361	144	207	70	101	-	11.4
EH 3/4	71	0.55	0.75	0.76	16	3.7	127	385	144	207	70	101	-	11.8
EH 3/5	71	0.75	1	0.91	16	4.3	151	409	144	207	70	101	-	12.4
EH 3/6	71	0.9	1.2	1.13	30	5.4	175	433	144	207	70	101	-	14.4
EH 3/7	71	1.1	1.5	1.28	30	6.0	199	457	144	207	70	101	180	15
EH 3/8	80	1.3	1.8	1.43	30	6.9	223	523	162	214	70	128	204	18.8
EH 3/9	80	1.5	2	1.58	30	7.5	247	547	162	214	70	128	228	19.4

3 ~ ELECTRIC PUMP TECHNICAL DATA

Pump model	Motor Size	MOTOR NOMINAL POWER		INPUT POWER [kW]	INPUT CURRENT [A]		Dimensions [mm]						Weight [Kg]	
		[kW]	[HP]		220-240 V	380-415 V	A	F	\varnothing B	H	L1	L2		L3
EH 3/2T	71	0.75	1	0.41	1.9	1.1	103	363	144	207	70	101	-	10.8
EH 3/3T	71	0.75	1	0.57	2.1	1.2	103	363	144	207	70	101	-	11
EH 3/4T	71	0.75	1	0.72	2.4	1.4	127	387	144	207	70	101	-	11.6
EH 3/5T	71	0.75	1	0.87	2.7	1.6	151	411	144	207	70	101	-	12
EH 3/6T	71	1.1	1.5	1.02	3.3	1.9	175	435	144	207	70	101	-	13.2
EH 3/7T	71	1.1	1.5	1.17	3.6	2.1	199	459	144	207	70	101	180	13.8
EH 3/8T	80	1.5	2	1.39	4.8	2.8	223	520	162	214	70	128	204	17.6
EH 3/9T	80	1.5	2	1.55	5.1	3.0	247	544	162	214	70	128	228	18.2

DIMENSIONAL DRAWINGS

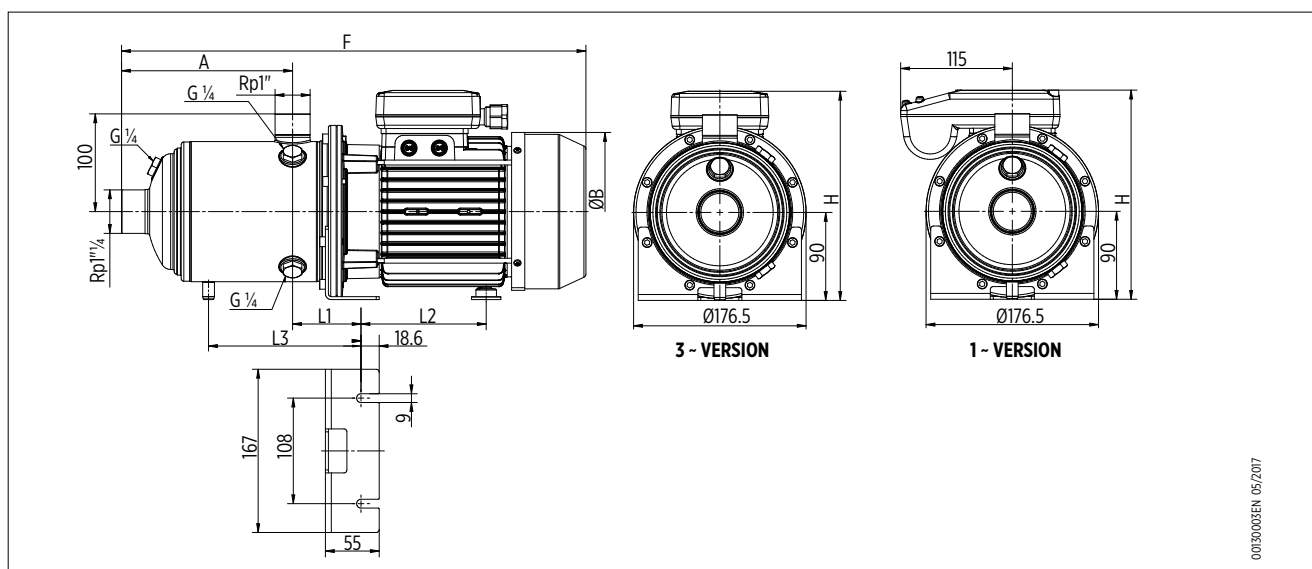

0030005EN 05/2017

EH 3 - PERFORMANCE CURVES 50 HZ

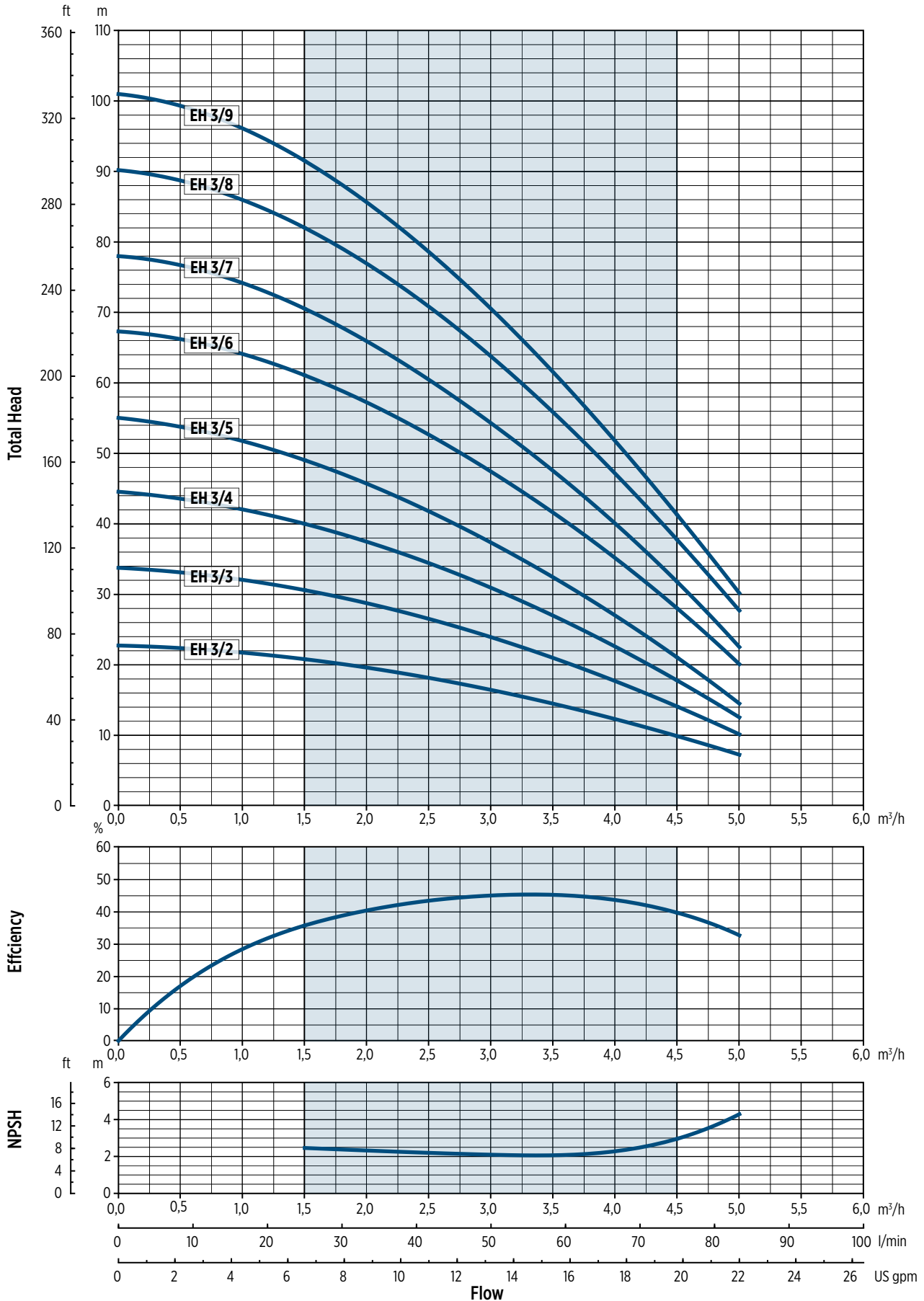

00720005 05/2017

EH 5 - TECHNICAL DATA

1 ~ ELECTRIC PUMP TECHNICAL DATA

Pump model	Motor Size	MOTOR NOMINAL POWER		INPUT POWER [kW]	Capacitor 450V μ F	INPUT CURRENT [A] 220-240 V	Dimensions [mm]						Weight [Kg]	
		[kW]	[HP]				A	F	\varnothing B	H	L1	L2		L3
EH 5/2	71	0.45	0.6	0.59	16	3.0	103	361	144	207	70	101	-	11.2
EH 5/3	71	0.55	0.75	0.81	16	3.9	103	361	144	207	70	101	-	11.4
EH 5/4	71	0.9	1.2	1.10	30	5.3	127	385	144	207	70	101	-	13.4
EH 5/5	71	1.1	1.5	1.32	30	6.2	151	409	144	207	70	101	-	14
EH 5/6	80	1.3	1.8	1.53	30	7.3	175	475	162	214	70	128	-	17.8
EH 5/7	80	1.5	2	1.74	30	8.2	199	499	162	214	70	128	180	18.2
EH 5/8	90	1.85	2.5	2.40	60	10.5	223	567	179	221	70	172	204	24.2
EH 5/9	90	2.2	3	2.59	60	11.4	247	592	179	221	70	172	228	24.8

3 ~ ELECTRIC PUMP TECHNICAL DATA

Pump model	Motor Size	MOTOR NOMINAL POWER		INPUT POWER [kW]	INPUT CURRENT [A]		Dimensions [mm]						Weight [Kg]	
		[kW]	[HP]		220-240 V	380-415 V	A	F	\varnothing B	H	L1	L2		L3
EH 5/2T	71	0.75	1	0.55	2.1	1.2	103	363	144	207	70	101	-	10.8
EH 5/3T	71	0.75	1	0.77	2.5	1.4	103	363	144	207	70	101	-	11
EH 5/4T	71	1.1	1.5	0.99	3.2	1.9	127	387	144	207	70	101	-	12.2
EH 5/5T	71	1.1	1.5	1.21	3.7	2.2	151	411	144	207	70	101	-	12.6
EH 5/6T	80	1.5	2	1.50	5.0	2.9	175	472	162	214	70	128	-	16.6
EH 5/7T	80	1.5	2	1.72	5.5	3.2	199	496	162	214	70	128	180	17
EH 5/8T	90	2.2	3	2.06	6.8	3.9	223	567	179	221	70	172	204	23
EH 5/9T	90	2.2	3	2.29	7.4	4.3	247	591	179	221	70	172	228	23.4

DIMENSIONAL DRAWINGS

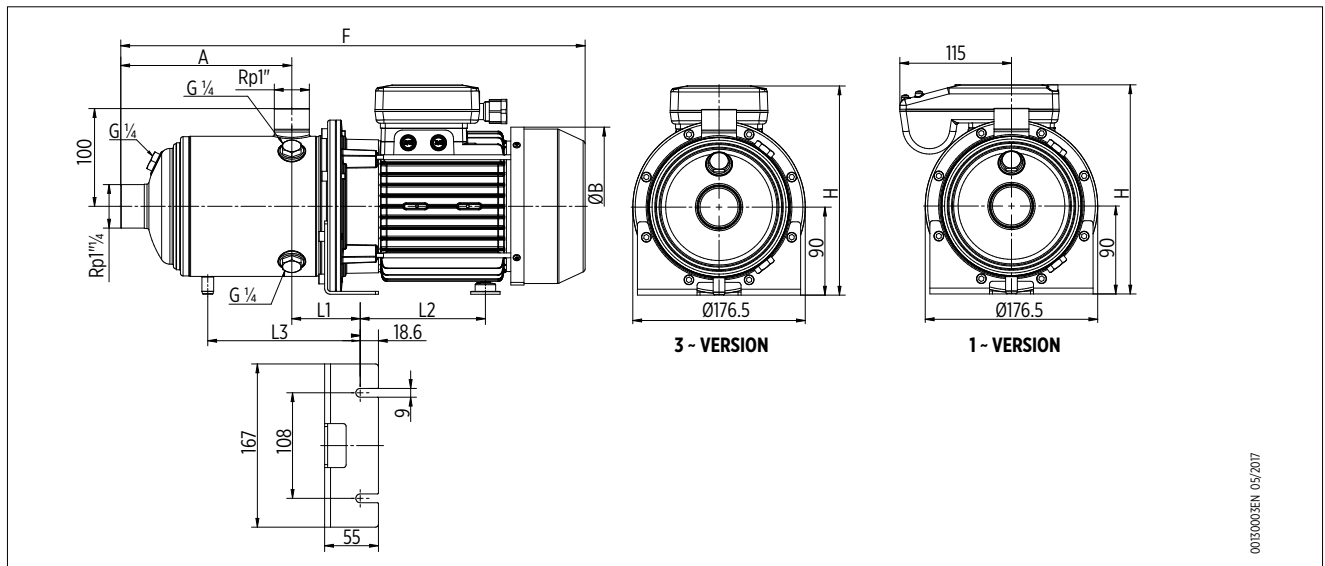

0030003EN 05/2017

EH 5 - PERFORMANCE CURVES 50 HZ

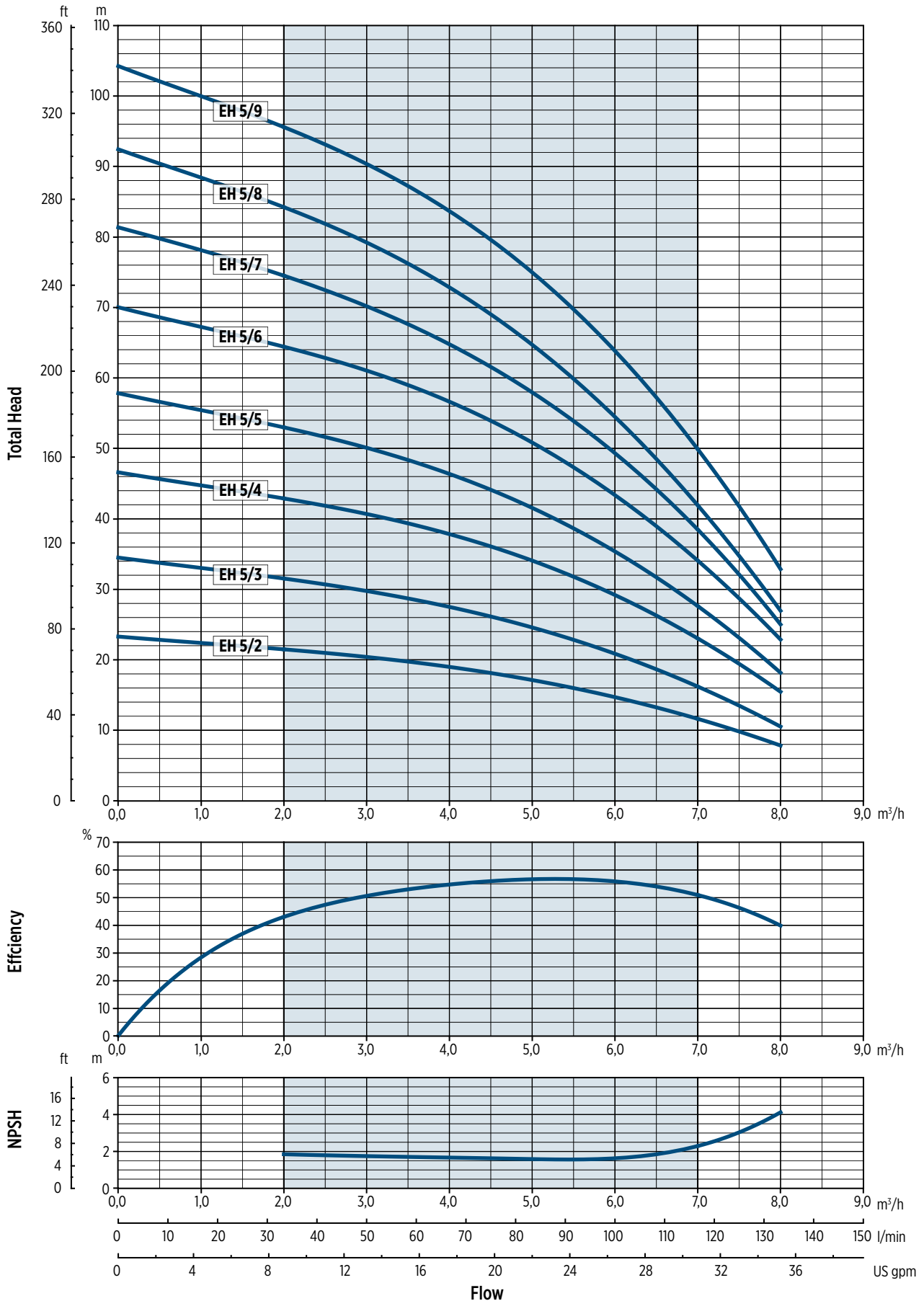

0072006-05/2017

EH 9 - TECHNICAL DATA

1 ~ ELECTRIC PUMP TECHNICAL DATA

Pump model	Motor Size	MOTOR NOMINAL POWER		INPUT POWER [kW]	Capacitor 450V μ F	INPUT CURRENT [A] 220-240 V	Dimensions [mm]						Weight [Kg]	
		[kW]	[HP]				A	F	\varnothing B	H	L1	L2		L3
EH 9/2	71	0.75	1	0.91	16	4.3	118	380	144	207	74	101	-	11.6
EH 9/3	71	1.1	1.5	1.35	30	6.3	118	380	144	207	74	101	-	13.2
EH 9/4	80	1.5	2	1.74	30	8.2	148	452	162	214	74	128	-	17
EH 9/5	90	2.2	3	2.51	60	11.1	178	527	179	221	74	172	-	23
EH 9/6	90	2.2	3	2.89	60	12.7	208	557	179	221	74	172	192	23.8
EH 9/7	90	2.2	3	3.30	60	14.5	238	587	179	221	74	172	222	24.4

3 ~ ELECTRIC PUMP TECHNICAL DATA

Pump model	Motor Size	MOTOR NOMINAL POWER		INPUT POWER [kW]	INPUT CURRENT [A]		Dimensions [mm]						Weight [Kg]	
		[kW]	[HP]		220-240 V	380-415 V	A	F	\varnothing B	H	L1	L2		L3
EH 9/2T	71	0.75	1	0.87	2.7	1.6	118	382	144	207	74	101	-	11.2
EH 9/3T	71	1.1	1.5	1.24	3.8	2.2	118	382	144	207	74	101	-	12
EH 9/4T	80	1.5	2	1.70	5.5	3.2	148	449	162	214	74	128	-	15.8
EH 9/5T	90	2.2	3	2.20	7.1	4.1	178	526	179	221	74	172	-	21.8
EH 9/6T	90	2.2	3	2.61	8.2	4.7	208	556	179	221	74	172	192	22.4
EH 9/7T	90	3	4	3.08	9.5	5.5	238	621	179	221	74	172	222	26
EH 9/8T	90	3	4	3.49	10.4	6.0	268	651	179	221	74	172	252	26.6

DIMENSIONAL DRAWINGS

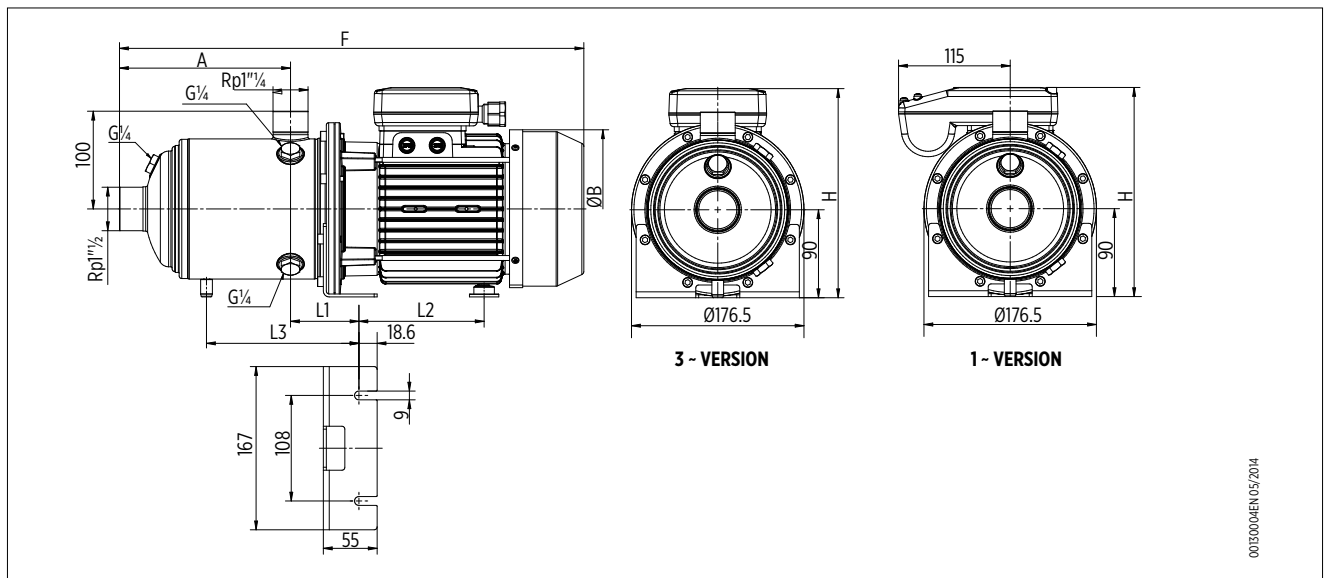

00130004EN/05/2014

EH 9 - PERFORMANCE CURVES 50 HZ

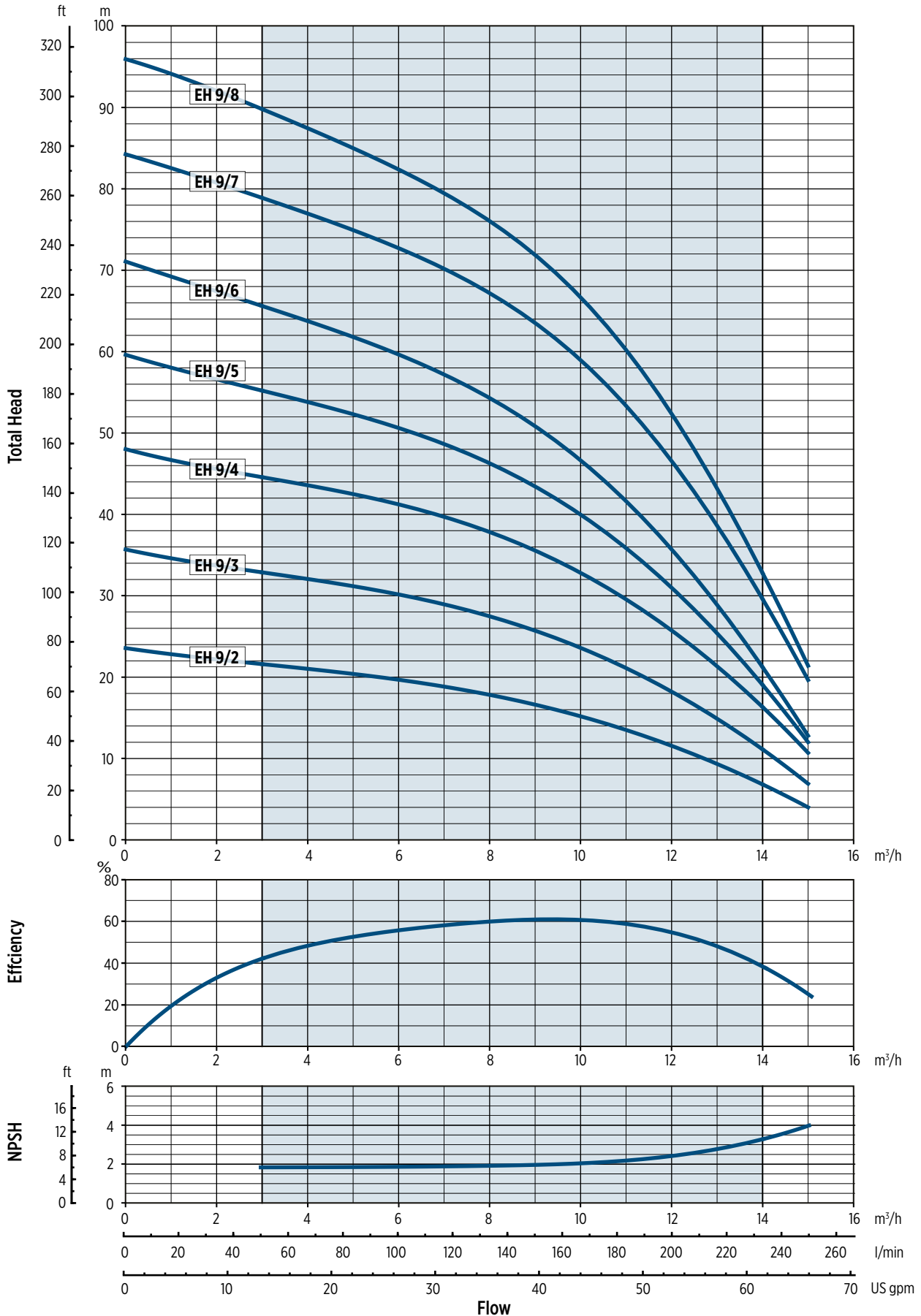

00120007/05/2017

EH 15 - TECHNICAL DATA

1 ~ ELECTRIC PUMP TECHNICAL DATA

Pump model	Motor size	MOTOR NOMINAL POWER		INPUT POWER [kW]	Capacitor 450V μ F	INPUT CURRENT [A] 220-240 V	Dimensions [mm]										Weight [Kg]	
		[kW]	[HP]				A	F	\varnothing B	H	H1	L1	L2	L3	M	N		N1
EH 15/2	80	1.5	2	1.63	30	7.7	144	488	162	224	100	113	129	-	-	-	-	20.2
EH 15/3	90	2.2	3	2.74	60	12.1	144	533	179	231	100	113	173	-	-	-	-	25.4

3 ~ ELECTRIC PUMP TECHNICAL DATA

Pump model	Motor size	MOTOR NOMINAL POWER		INPUT POWER [kW]	INPUT CURRENT [A]			Dimensions [mm]										Weight [Kg]	
		[kW]	[HP]		220-240 V	380-415 V	660-690 V	A	F	\varnothing B	H	H1	L1	L2	L3	M	N		N1
EH 15/2T	80	1.5	2	1.60	5.3	3.0	-	144	485	162	224	100	113	129	-	-	-	-	18.8
EH 15/3T	90	2.2	3	2.45	7.8	4.5	-	144	532	179	231	100	113	173	-	-	-	-	24.4
EH 15/4T	90	3	4	3.28	9.9	5.7	-	192	615	179	231	100	113	173	-	-	-	-	28.6
EH 15/5T	100	4	5.5	4.09	-	7.0	4.1	240	670	194	246	100	150	-	279	170	160	192	37
EH 15/6T	112	5.5	7.5	4.95	-	9.3	5.4	288	732	218	263	112	152	-	329	180	190	220	46.2
EH 15/7T	112	5.5	7.5	5.71	-	10.3	6.0	336	780	218	263	112	152	-	377	180	190	220	47.6

DIMENSIONAL DRAWINGS

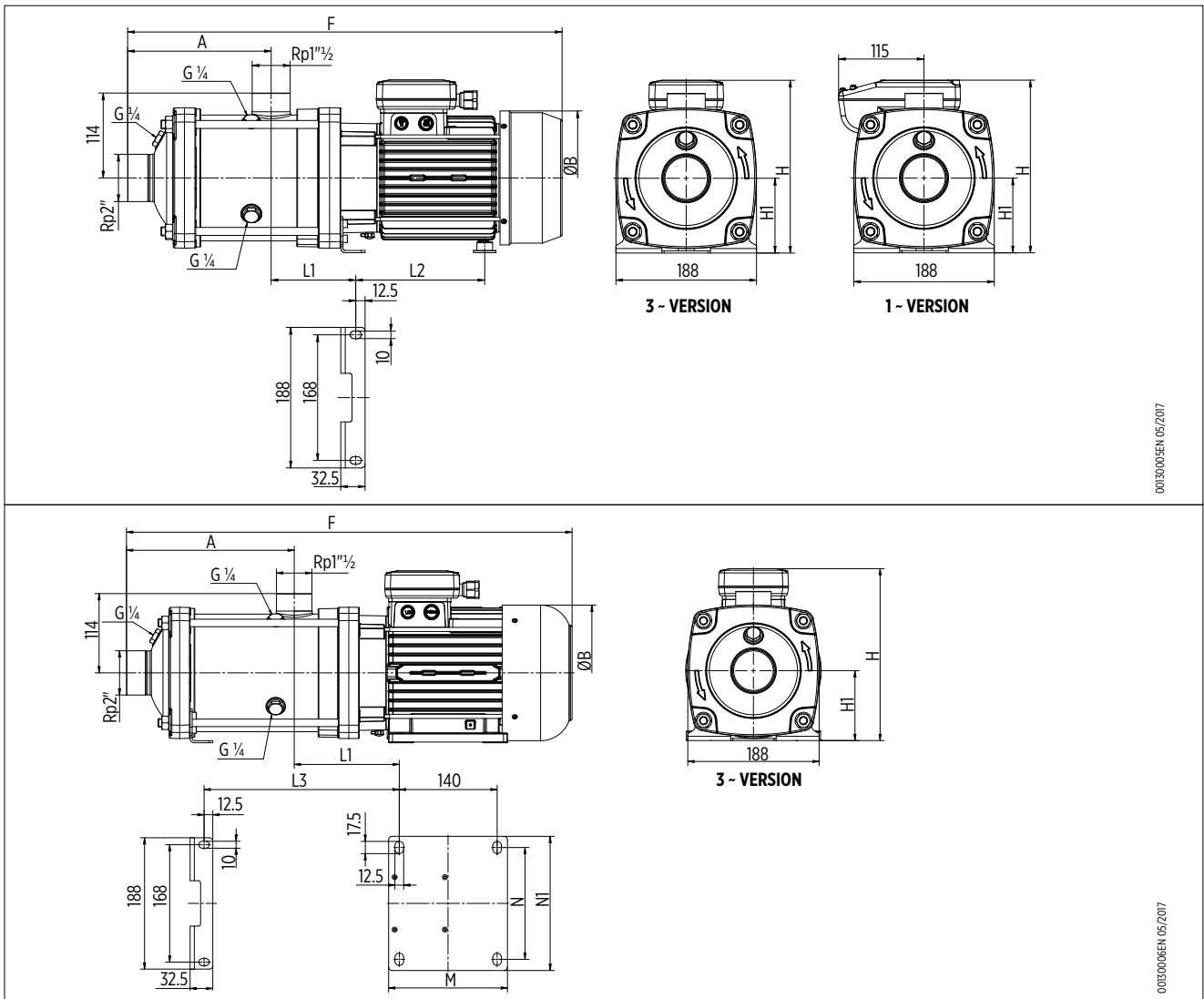

EH 15 - PERFORMANCE CURVES 50 HZ

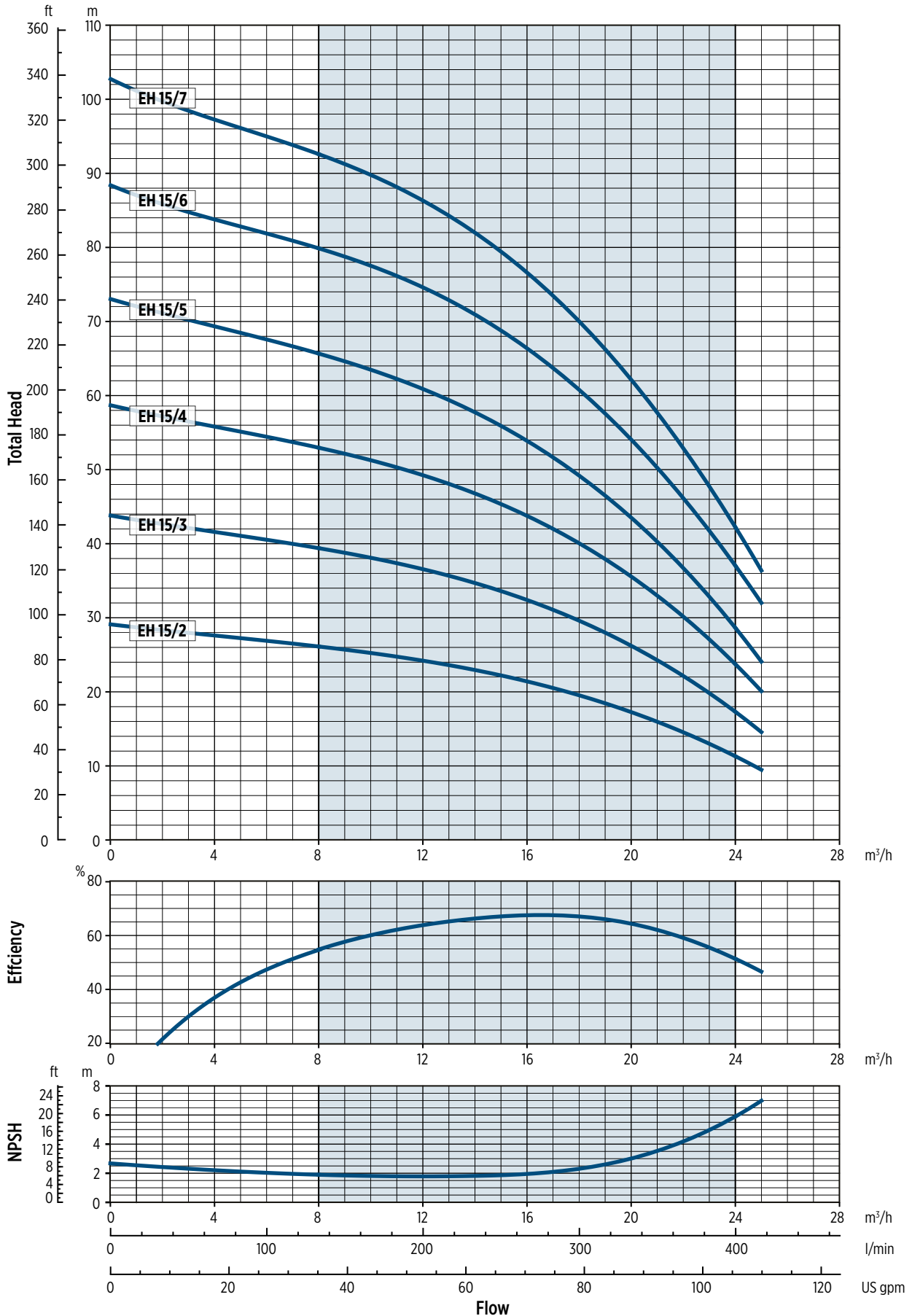

EH 20 - TECHNICAL DATA

1 ~ ELECTRIC PUMP TECHNICAL DATA

Pump model	Motor size	MOTOR NOMINAL POWER		INPUT POWER [kW]	Capacitor 450V μ F	INPUT CURRENT [A] 220-240 V	Dimensions [mm]										Weight [Kg]	
		[kW]	[HP]				A	F	\varnothing B	H	H1	L1	L2	L3	M	N		N1
EH 20/2	90	2.2	3	2.59	60	11.4	144	533	179	231	100	113	173	-	-	-	-	25.2

3 ~ ELECTRIC PUMP TECHNICAL DATA

Pump model	Motor size	MOTOR NOMINAL POWER		INPUT POWER [kW]	INPUT CURRENT [A]			Dimensions [mm]										Weight [Kg]	
		[kW]	[HP]		220-240 V	380-415 V	660-690 V	A	F	\varnothing B	H	H1	L1	L2	L3	M	N		N1
EH 20/2T	90	2.2	3	2.29	7.4	4.3	-	144	532	179	231	100	113	173	-	-	-	24.2	
EH 20/3T	90	3	4	3.43	10.3	5.9	-	144	567	179	231	100	113	173	-	-	-	27.2	
EH 20/4T	100	4	5.5	4.53	-	7.7	4.4	192	622	194	246	100	150	-	231	170	160	192	35.8
EH 20/5T	112	5.5	7.5	5.69	-	10.3	6.0	240	684	218	263	112	152	-	281	180	190	220	45

DIMENSIONAL DRAWINGS

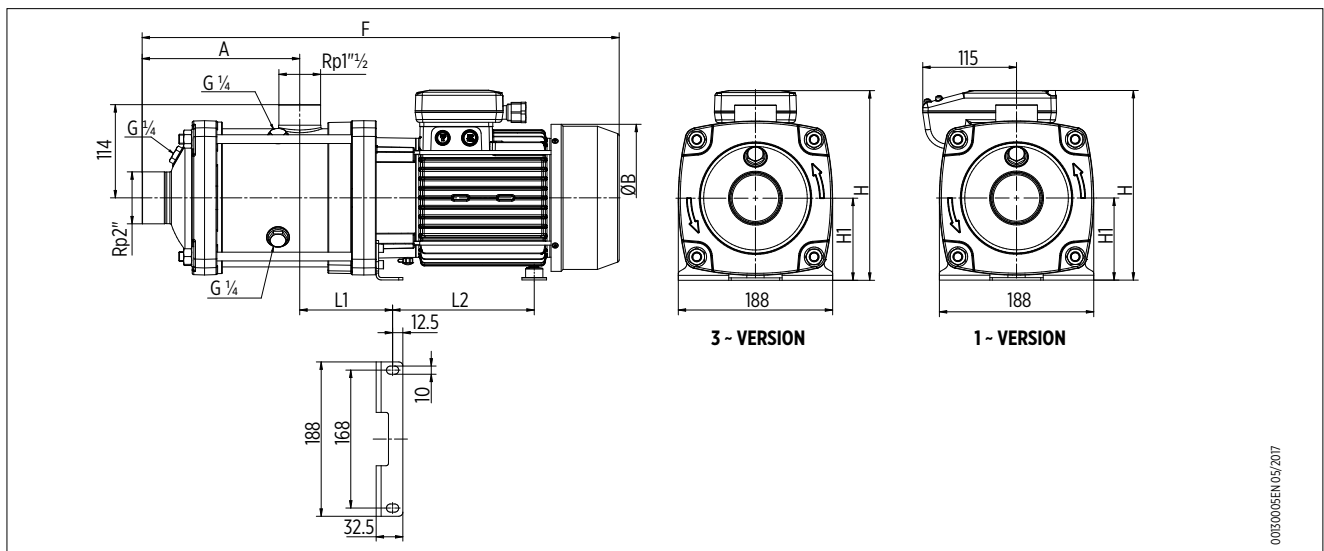

0030005EN 05/2017

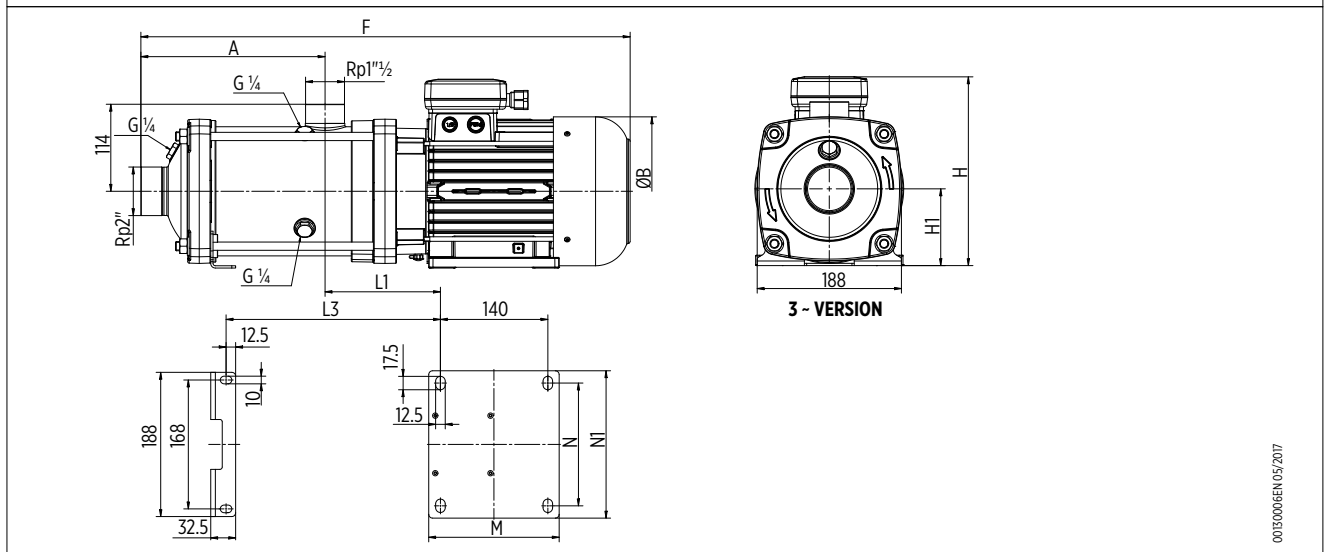

0030006EN 05/2017

EH 20 - PERFORMANCE CURVES 50 HZ

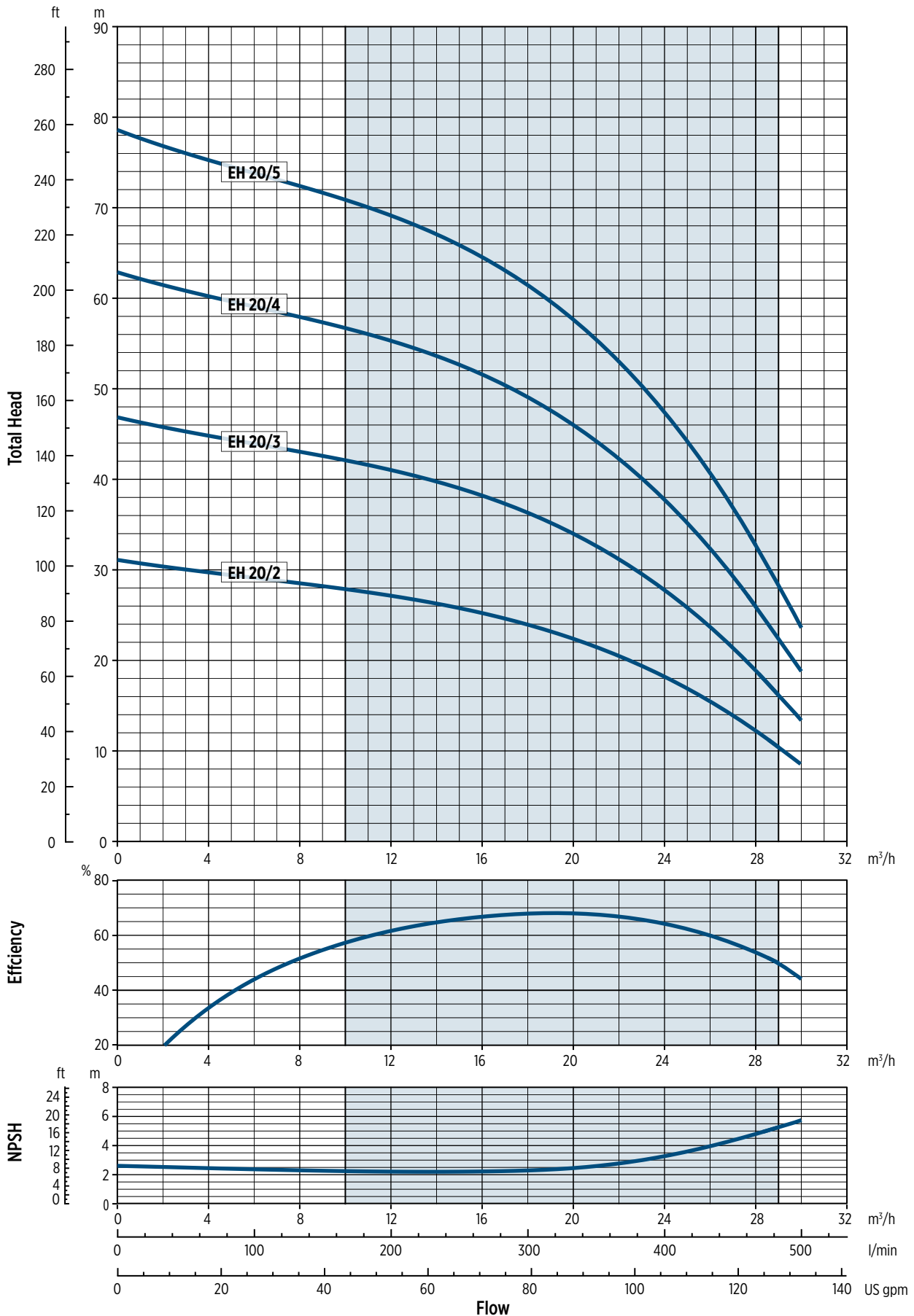



EHsp Series

Technical data and performance curves

EHsp 3 - TECHNICAL DATA

1 ~ ELECTRIC PUMP TECHNICAL DATA

Pump model	Motor size	MOTOR NOMINAL POWER		INPUT POWER [kW]	Capacitor 450V μ F	INPUT CURRENT [A] 220-240 V	Dimensions [mm]		Weight [Kg]
		[kW]	[HP]				A	F	
EHsp 3/4	71	0.55	0.75	0.79	16	3.8	175	433	12.6
EHsp 3/5	71	0.75	1	0.95	16	4.5	199	457	13

3 ~ ELECTRIC PUMP TECHNICAL DATA

Pump model	Motor size	MOTOR NOMINAL POWER		INPUT POWER [kW]	INPUT CURRENT [A] 220-240 V	Dimensions [mm]		Weight [Kg]
		[kW]	[HP]			A	F	
EHsp 3/4 T	71	0.75	1	0.75	2.4	175	435	12.2
EHsp 3/5 T	71	0.75	1	0.91	2.8	199	459	12.8

DIMENSIONAL DRAWINGS

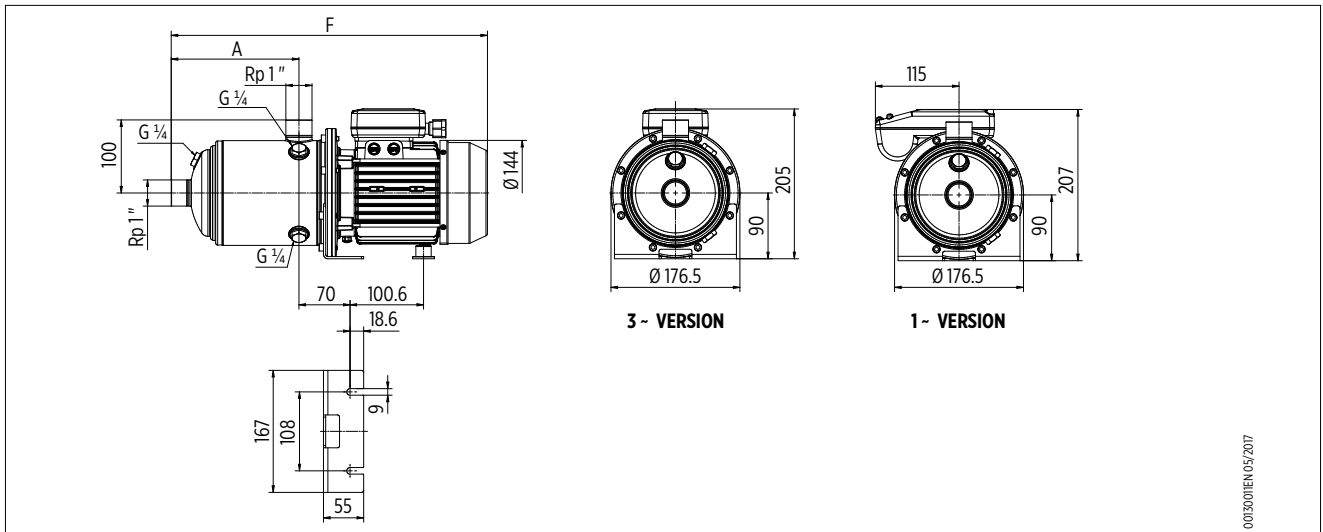

EHsp 3 - PERFORMANCE CURVES 50 HZ

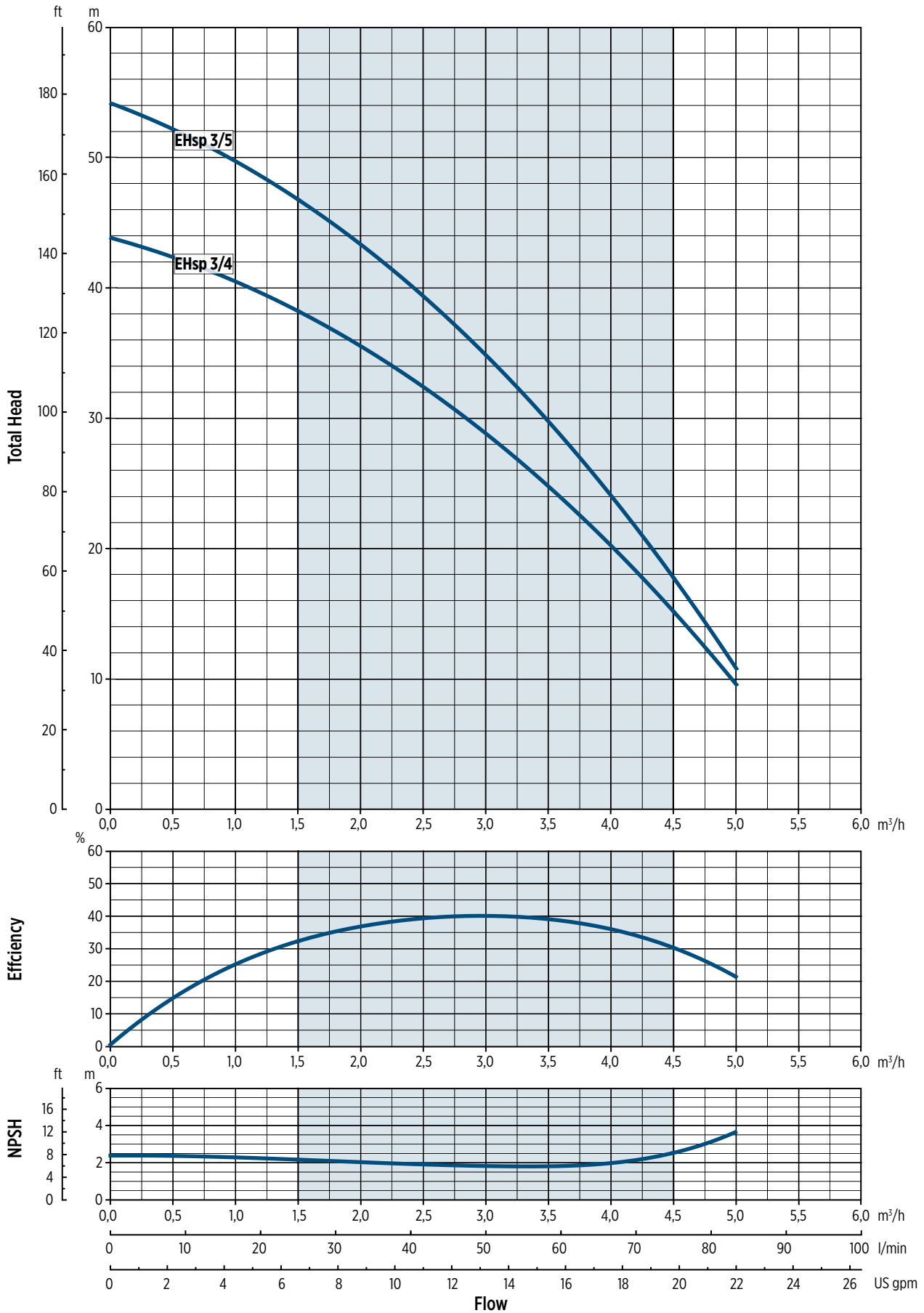

0020001 05/2017

EHsp 5 - TECHNICAL DATA

1 ~ ELECTRIC PUMP TECHNICAL DATA

Pump model	Motor size	MOTOR NOMINAL POWER		INPUT POWER [kW]	Capacitor 450V μ F	INPUT CURRENT [A] 220-240 V	Dimensions [mm]		Weight [kg]
		[kW]	[HP]				A	F	
EHsp 5/4	71	0.9	1.2	1.10	30	5.3	175	433	14
EHsp 5/5	71	1.1	1.5	1.31	30	6.1	199	457	14.4

3 ~ ELECTRIC PUMP TECHNICAL DATA

Pump model	Motor size	MOTOR NOMINAL POWER		INPUT POWER [kW]	INPUT CURRENT [A] 220-240 V	Dimensions [mm]		Weight [Kg]
		[kW]	[HP]			A	F	
EHsp 5/4 T	71	1.1	1.5	0.99	3.2	175	435	12.8
EHsp 5/5 T	71	1.1	1.5	1.20	3.7	199	459	13.4

DIMENSIONAL DRAWINGS

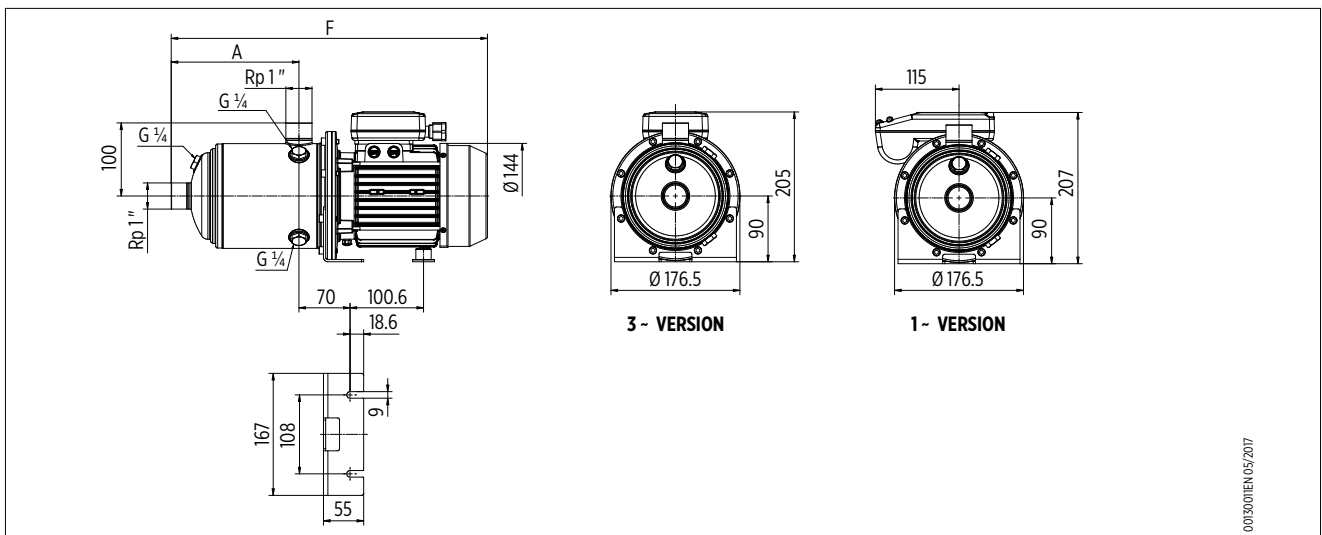

EHsp 5 - PERFORMANCE CURVES 50 HZ

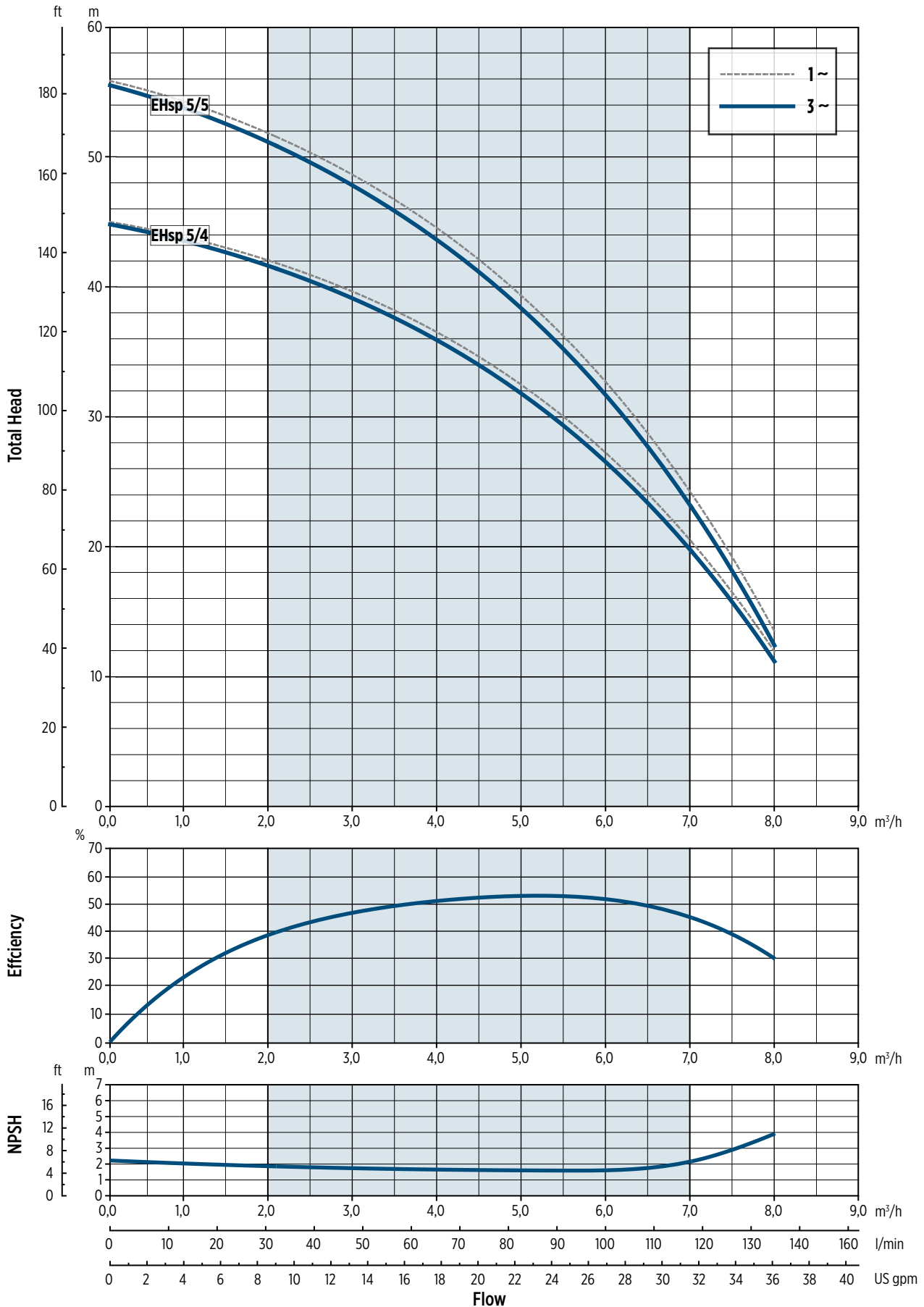

0020010 05/2017



Franklin Electric

Franklin Electric S.r.l.
Via Asolo, 7 - 36031 Dueville (Vicenza) - ITALY
Phone: +39 0444 361114 - Fax: +39 0444 365247
Email: sales.it@fele.com

Single member - Company subject to the control and coordination of Franklin Electric Co., Inc.

Franklin Electric S.r.l. reserves the right to amend specification without prior notice

00103890 EN_REV06_10/2019

franklinwater.eu